

MATERIALS

BODY	NICKEL PLATED BRASS
CONTACT	GOLD PLATED BRASS
INSULATOR	PTFE

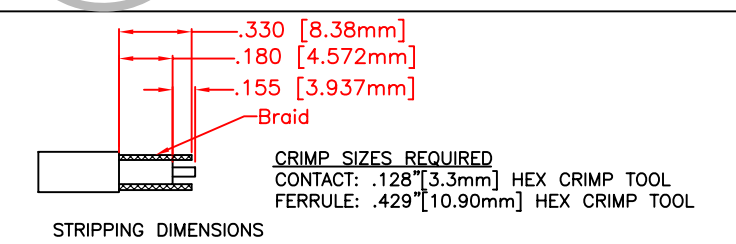
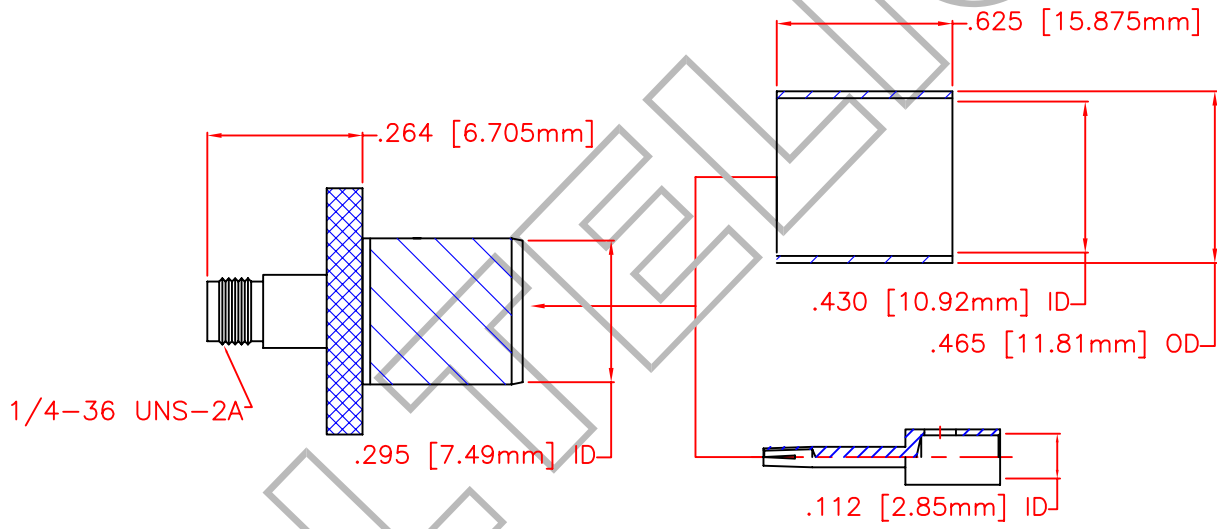

- NOTES:
1. UNLESS OTHERWISE SPECIFIED ALL DIMENSIONS ARE NOMINAL.
 2. ALL SPECIFICATIONS ARE SUBJECT TO CHANGE WITHOUT NOTICE AT ANY TIME.

				SIZE	TITLE:
				A	Crimp: RP-SMA-Jack for Cable Group 4

REV	ECN No.	DATE	DESCRIPTION	DRAWN BY	M. Audas 10/31/06	DRAWING No.	REV
				ORIGINATOR	M. Audas 10/31/06	ARSJ-1404	A
				APPROVAL	P. Pesa 10/31/06	PART No. ARSJ-1404	
				SCALE	NTS SHEET 1/1	MATERIAL	Noted
						FILE No.	ARSJ-1404