

ComEx potentiometer module

for panel- and railmounted installation



ComEx potentiometer module

for panel- and railmounted installation



Note on instructions

When working in hazardous areas, the safety of personnel, environment and equipment depends on compliance with the relevant safety regulations. The people in charge of installation and maintenance bear a special responsibility. It is essential that they have an exact knowledge of the applicable rules and regulations.

The instructions provide a summary of the most important safety measures and must be read by everyone working with the product so that they will be familiar with the correct handling of the product.

The instructions have to be kept for future reference and must be available throughout the expected life of the product.

Description

The ComEx potentiometer module is used in almost all hazardous (potentially explosive) areas where machine functions are controlled by means of adjustable voltage distributors. The module can be combined with a potentiometer actuator (scale graduation 0 to 10) and is available in versions with 1 kΩ and 10 kΩ.

All contacts of the ComEx potentiometer module are self-cleaning, and the NC contacts feature positive opening. The connecting cable is connected to the ComEx potentiometer module via screw terminals. The ComEx potentiometer module offer the option of simple and fast mounting on a rail or a panel mounted installation per direct mounting to the ComEx actuator. The ComEx potentiometer modules are developed and certified for globally market.

Explosion protection

Notified Body Number	CE 0044
Approved Body Number	2503
ATEX/UKEX Ex protection type	Ⓜ II 2G Ex db eb IIC Gb Ⓜ I M2 Ex db eb I Mb
ATEX/UKEX certificate number	CML 22 ATEX 1135 U CML 22 UKEX 1136 U
IECEX Ex protection type	Ex db eb IIC Gb Ex db eb I Mb
IECEX certificate number	IECEX CML 22.0014 U
CEC (UL Mark)	Ex db eb IIC Gb Class I, Division 2, Groups A, B, C, D
NEC (UL Mark)	Class I, Zone 1, AEx db eb IIC Gb Class I, Division 2, Groups A, B, C, D
Certification	UL E184198
Operating temperature ranges	-55 °C to +85 °C (-67 °F to +185 °F)

For further approvals and certificates, see www.bartec.com

Technical data

Max. ambient temperature only with protection by flame- proof enclosure "d"	+85 °C (+185 °F)
Degree of protection	IP20 acc. to EN 60529
Rated voltage (U)	250 V
Rated insulation voltage (Ui)	250 V
Rated power dissipation	up to 1 W
Resistance	1 kΩ 10 kΩ
Curve shape	linear
Resistor material	carbon film on ceramics
Rotation	mechanical: 285° to 5° electrical: approx. 250°
Rated torque	0.4 - 0.7 Nm (0.3 - 0.5 lb.ft)
Enclosure material	Thermoplastic
Connection	0.75 mm ² - 2.5 mm ² /18 AWG - 12 AWG
Storage and transport temperature	-55 °C to +85 °C (-67 °F to +185 °F)
Mechanical life	25,000 sinusoidal cycles
Weight	Panelmounted: approx. 110 g Railmounted: approx. 71 g
Mounting	Panelmounted (locked with potentiometer actuator 07-3400-D100 by bayonet lock) Railmounted (latched on mounting rail NS 35 x 7.5)
Shock resistance	DIN EN/IEC 60068-2-27, 30 g 18 ms



Safety Instructions

The ComEx potentiometer modules and the corresponding actuator may be used only within the specified ambient and operating temperature range. Incorrect installation can cause malfunctioning and the loss of explosion protection. Utilisation in areas other than those specified or the alteration of the product by anyone other than the manufacturer will exempt BARTEC from liability for defects or any further liability. Only service technicians who are authorized to work in potentially explosive atmospheres may do any of the assembly, disassembly, installation, commissioning, maintenance, and fault clearance work.

The generally applicable statutory rules and other binding directives relating to workplace safety, accident prevention and environmental protection must be observed.

When using electrical systems the relevant regulations on installation and operation must be complied with.

When setting up or operating explosion-resistant electrical systems, the IEC/EN 60079-14 (NEC for USA/CEC for Canada) and all relevant installation and operating regulations must be observed.

The ComEx potentiometer modules may be used only if it is in a clean and undamaged condition. It is not permissible to modify the ComEx potentiometer modules in any way.

Marking

Particularly important points in these instructions are marked with a symbol:



DANGER indicates a hazardous situation which, if not avoided, will result in death or serious injury.



WARNING indicates a hazardous situation which, if not avoided, could result in death or serious injury.



CAUTION indicates a hazardous situation which, if not avoided, could result in minor or moderate injury.



NOTICE is used to address practices not related to personal injury.



NOTE Important instructions and information on effective, economical and environmentally compatible handling.

Standards conformed to

Please see the Attestation of Conformity.

Transport, Storage



NOTICE

The ComEx potentiometer modules damage through incorrect transport or incorrect storage.

- Transport and storage is permissible in original packaging only.
- Store the ComEx potentiometer modules in a dry place.

Assembly, Installation



WARNING

Risk of serious injury due to incorrect proceedings.

- The IEC/EN 60079-14 and further national standards and locally applicable installation regulations have to be observed.
- Ensure that the voltage supply has been isolated or take suitable protective measures.
- Pay attention to the type of mounting required (for fitting into enclosure).

Assembly



WARNING

Risk of serious accidents due to damaged parts.

- Before assembly, ensure the perfect condition of the components.

Mounting the ComEx potentiometer module for panelmounted:

- Make sure the ComEx potentiometer module for panelmounted to be fitted is intact (no cracks).
- Position the ComEx potentiometer's bayonet connector at the mounted actuating element.
- Turn the closing latch to connect the ComEx potentiometer securely to the potentiometer actuating element.

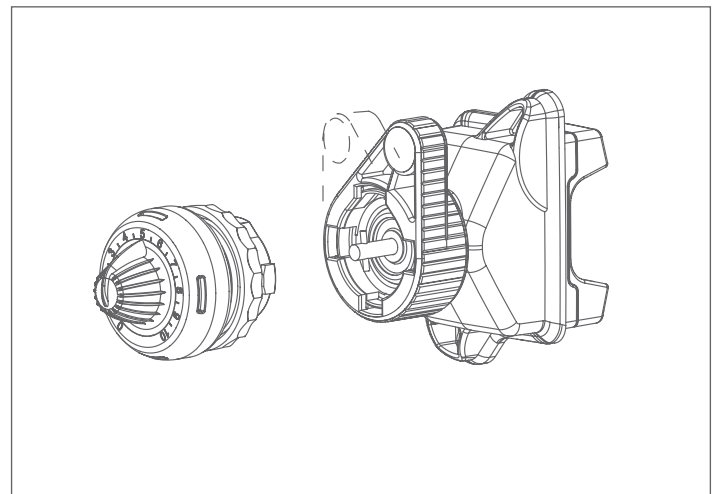

Mounting the potentiometer for railmounted:

- Make sure the potentiometer to be fitted is intact (no cracks).
- Put the potentiometer on the mounting rail NS 35/7.5.
- Align the position of the potentiometer on the mounting rail at the actuator.

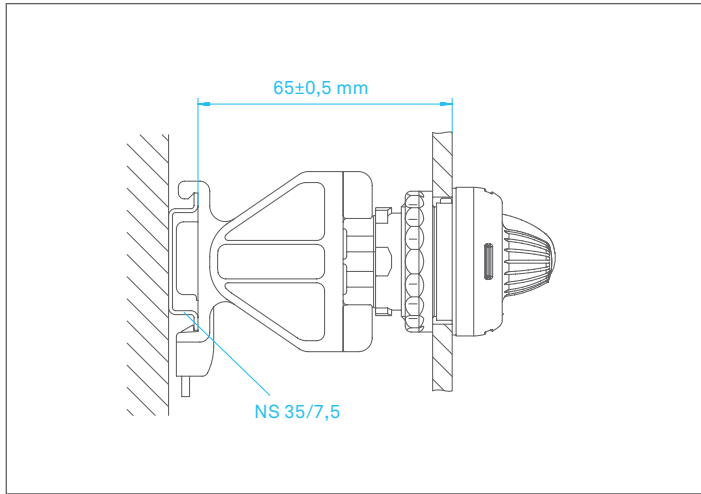

i **NOTE** The assembly of the potentiometer actuating element is described in the operating instructions for actuating elements, type 07-3400-D100.

Installation

Specific Conditions of Use

The following conditions relate to safe installation and/or use of the equipment.

- The modules that complies with IEC 60079-7, shall be installed in an enclosure which meets the requirements of a recognised type of protection as specified in Section 1 of IEC 60079-0. When the modules are installed in an increased safety enclosure that complies with IEC 60079-7, the creepage and clearance distances shall comply with the standard requirements. The actual maximum rated current resp. power dissipation of the modules shall be determined in the type test of the electrical equipment concerned. When the module is used in a mine susceptible to firedamp (Group I), the maximum rated current shall not exceed 16 A.
- The modules that complies with IEC 60079-11, shall be installed in such a way that it is protected by an enclosure that complies at least with the requirements of IEC 60079-0 clause 26.4.2 and excludes the risk of mechanical damage. The separation distances to the module terminals shall be comply with the standard requirements.
- The service temperature of the modules shall be within -55 °C to +85 °C. The service temperature of the locking device for the modules type 07-33*4-4***/** shall not exceed +70 °C.
- Each terminal of the module is limited to one conductor per clamping unit.

- The modules shall be installed in accordance with manufacturers documentation.

Take care when connecting conductors:

- Strip 40 mm (1.6 in) sheath off the conductor.
- Remove approx. 6 mm (0.2 in) conductor insulation from the cores.
- Prepare the ends of fine-stranded and multi-stranded conductors: Crimp wire end sleeves with suitable crimping tools. Connection cross-sections: 0.75-2.5 mm² (14-18 AWG).
- Release terminals.
- Mount the conductor in the clamp.
- Tighten the terminals with a torque of 0.4-0.7 Nm (0.3-0.5 lb.ft).

Commissioning

Before commissioning, check that:

- The ComEx potentiometer modules has been installed in compliance with regulations.
- The ComEx potentiometer modules is not damaged.
- The connection has been established properly (make sure the cores are secure).

Terminal assignment:

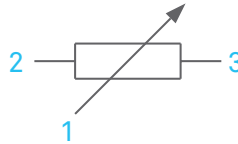

Resistance:

Type 07-3374-4D40	1 kΩ
Type 07-3374-4D70	10 kΩ
Type 07-3372-1D40	1 kΩ
Type 07-3372-1D70	10 kΩ

Operation



WARNING

Risk of serious accidents due to operation without an actuator.

- The ComEx potentiometer may never be operated without an actuator at rated voltages > AC 50 V to a max. AC/DC 320 V.
- If the ComEx potentiometer does not have an actuator, it must be deenergized.

The ComEx potentiometer may be operated without an actuator only at rated voltages of ≤ AC 50 V resp. < DC 120 V.

Maintenance and Fault Clearance



WARNING

Risk of serious injury due to incorrect proceedings.

- IEC/EN 60079-17 must be observed. It is recommended to formulate a maintenance plan according to this standard.
- Ensure that the voltage supply has been isolated or take suitable protective measures.

Maintenance



WARNING

Risk of serious accidents due to damaged parts.

- Check potentiometer, screw fittings and cables regularly for cracks and damage. Make sure that they are properly established.
- Functional and recurring inspections must be conducted at regular intervals. The plant operator must define the test intervals for the respective application. The properties of AgSnO₂ contacts must be taken into account in the case of low supply voltage (DC 24 V) and long periods between actuation. I.e. used in applications with low voltage/low current, such as PLC signal-switching, and in saline or other corrosive environments it is recommended to increase test interval frequency to minimum once per year.



NOTICE

Potentiometer element damage due to incorrect cleaning.

- It is not allowed to clean ComEx potentiometer modules/actuators with compressed air.

The operator of the ComEx potentiometer must keep it in good condition, operate it properly, monitor it and clean it regularly. The owner/managing operator must schedule maintenance intervals which will suit the respective conditions of use.

Fault Clearance



WARNING

Risk of serious injury due to use of non-original spare parts.

- Use original parts only as replacements.

The ComEx potentiometer modules is defective if turning it does not lead to a change in resistance.

Defective ComEx potentiometer modules cannot be repaired; they must be replaced considering this operational instruction.



NOTE For original parts, contact the firm of Bartec GmbH at the service address.

Disposal



NOTE Environmental damage can be caused by incorrect waste disposal. When in doubt, local authorities or specialist disposal companies can provide information on environmentally friendly disposal.

The components in the ComEx potentiometer modules contain metal and plastic parts. Therefore the statutory requirements for disposing of electronic scrap must be observed.

Installation dimensions



NOTICE

Damage to elements due to incorrect installation dimensions.

- The minimum spacing between the mounting holes must be observed.

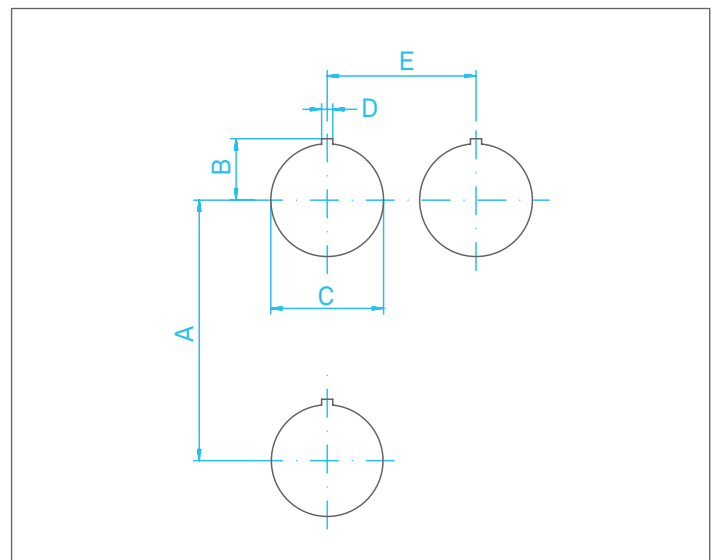

Dimensions:

	mm	in
A	75	2.95
B	16.5	0.65
C	$\varnothing 30.3^{+0.3}$	$\varnothing 1.2^{+0.01}$
D	3	0.12
E	40	1.6

Dimensions in mm

ComEx potentiometer module for railmounted 07-3372-1D*

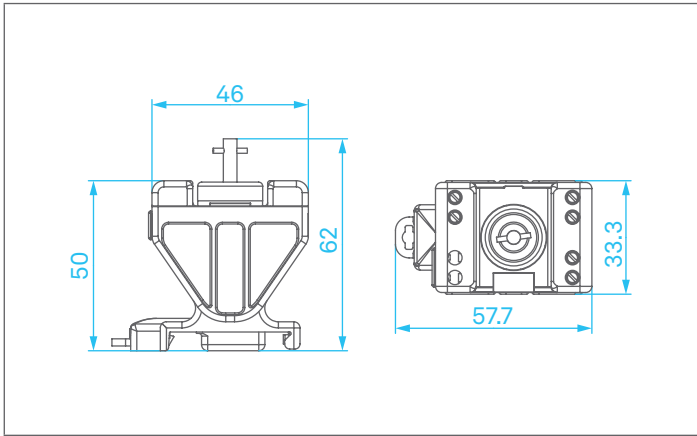

Dimensions in mm

ComEx potentiometer module for panelmounted 07-3374-4D*

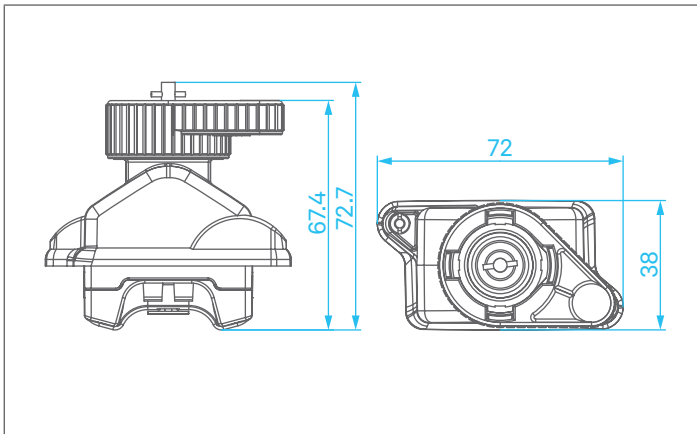

Service-Address

BARTEC GmbH
 Max-Eyth-Str. 16
 97980 Bad Mergentheim
 Germany

Phone: +49 7931 597-0
 info@bartec.com



BARTEC

BARTEC GmbH
Max-Eyth-Str. 16
97980 Bad Mergentheim
Germany

Tel.: +49 7931 597-0
info@bartec.com

bartec.com