



Operating Instructions

Optical point sensor PSO+ and PSO Type: 17-85M6-1102.A00

Intended use

The PSO+ point sensor and the PSO point sensor are components of the BARTEC water detection system. They can be combined with the SCR sensor cable and/or the PS point sensor. The RLW, RLA^{net}, RDW03 and RDA01 electronic monitoring systems as well as corresponding accessories (see catalogue) are also part of the BARTEC water detection system.

Product description

General information

The point sensor is used to detect electrically non-conductive liquids such as oil, enabling the location of the leak to be detected quickly.

Thanks to the special optics, it can operate reliably also when facing metallic surfaces (e.g. oil catch pan made of sheet steel).

The PSO point sensor consists of a PVC sensor enclosure with three spacer feet. In conjunction with the BARTEC electronic monitoring system (e.g. RDW, RDA, RLW or RLA), an alarm is signalled as from a leak height of 2 mm (height can be adjusted using the screw feet).

The removable enclosure lid permits free access to the terminals. Up to 50 sensors can be connected in series. An integrated final resistance makes it possible to monitor cable breaks.

The integrated load relay can operate actuators, such as a check valve, directly on site. A second changeover contact reports the circuit state to the electronic monitoring system

Difference between PSO+ and PSO

The PSO+ point sensor and PSO can be supplied centrally with DC 24 V via the signal cable. It is similarly possible to provide a decentralised power supply by means of a commercially available plug-in power supply unit.

With its additional terminal block, the PSO+ point sensor can be combined with the SCR and PS sensors as required. In addition, this terminal block and the integrated series resistors with R = 62 Ω corresponding to 10 m sensor cable permits the positioning function (with RLA^{net} or RLW).

Safety instructions

- Before commissioning, please make certain that the PSO+ and the PSO are suitable for the designated use.
- For electrical installations, the pertinent installation and operating regulations must be followed (e.g. DIN VDE 0100 series or other relevant national regulations).
- All general statutory regulations and other binding guidelines on occupational health and safety, accident prevention and environmental protection must be complied with.

Assembly and commissioning

Assembly

The device must be positioned in a suitable place where leaked liquid can collect. This is aided by a catch pan with a ridge.

Installation

The device must be connected according to the circuit diagram, complying with the specified current/voltage data. The ends of the conductors should be appropriately prepared when connecting stranded or finely stranded conductors.

Plug-in connections on the installation path must be laid so they remain dry. For this purpose, the customer must insert spacers between the conductor and the ground when monitoring areas.

Commissioning

The device may only be operated in a clean and undamaged condition. If damage is visible, the device must be taken out of service and corresponding repair measures must be initiated.

Commissioning must be performed in the following steps:

- Connect the device to the power supply
- The green LED indicates that voltage is ON
- The red LED signals that the relay is active (fail-safe circuit), when the optics are in the open
- If the optics are immersed in the leaked liquid, the relay sinks and the red LED is extinguished

Operation, maintenance

The company operating an electrical installation must keep the operating equipment in good condition, must operate and monitor it as intended, and must carry out maintenance and repair work.

All electrical equipment must be selected according to its suitability. Applicable laws and guidelines must be followed before putting it back into operation. The specified safety instructions must be observed before maintenance and/or troubleshooting.

It is necessary to ensure that the optics of the PSO+ and of the PSO are kept clean and free of grease at intervals that are suitable considering the degree of soiling or dust to be expected.

Alarm management

Alarm output

The isolated relay output is primarily used as group alarm output in the closed current/NC = normally closed" operating mode. This means the contact remains closed (relay is activated) as long as there are no faults. This operating principle enables wire breaks and power failures to be detected (1).

Function table

Leaking fluid	not available	available
PSO+/PSO	ready	alarm
Operating condition		
LED rot „ready“	ON	OFF
Relay coil	current	currentless
Relay contact NO - C	closed (1)	open
Relay contact NC - C	open	closed (2)

Measuring circuit monitoring

The connected point sensor is transmitted to electronic monitoring system (e.g. RDW, RDA, RLW or RLA) via the relay contact NC - C. This also allows the parallel connection of several point sensors (2).

In addition, the measuring circuit is monitored for the following errors:

- Interruption of the measuring circuit

If this error occurs, the load circuit is opened and a corresponding fault message generated.

Technical data

Measuring method	Visual: from 2 mm; Can be adjusted higher using screw feet
Ambient temperature range	-25 °C to +50 at 5 % to 95 % air humidity (non-condensing) Optics und screw feet (leaked liquid): -25 °C to +80 °C -40 °C to +125 °C (on request)
Storage temperature	-30 °C to +60 °C
Enclosure	PVC
Terminals	Screw terminals; max. 1.5 mm ²
Dimensions	Ø 80 x 70 mm (D x H)) without cable glands
Fixing	Free-standing, floor installation
Protection class	IP 65/67
Installation position	Upright, optics pointing straight down
Weight	PSO+: approx. 270 g PSO: 240 g

Electrical data

Rated voltage	DC 24 V +/-10 %, 0.4 W
Outputs	Group alarm relay, 2 changeover contacts DC-13: 1 A, 24 V Fail-safe, relay is activated Change-over contact: NO – C terminals open if leak is detected
Internal display	LED green: voltage ON LED red: relay activated, no leak

Electrical connection/device connections PSO+

-X1 (screw terminals, for series connection, via installation cable, e.g. LIYY)

Terminals 1, (+R = 62 Ω) 5	Measuring circuit e.g. LIYY white
Terminals 2, 6	Reference measuring circuit e.g. LIYY brown (for positioning)
Terminals 3, (+R = 62 Ω) 7	Measuring circuit e.g. LIYY green
Terminals 4, 8	Reference measuring circuit e.g. LIYY yellow (for positioning)
Terminals 5, 7	Integrated terminal resistor 220 kΩ Is removed during series connection, apart from last PSO+ Last PSO+ with terminal resistor for RDA or RDW Last PSO+ terminal jumpers (5/6 and 7/8) for RLA ^{net} or RLW

-X2 (Screw terminals, power supply and floating changeover contacts via installation cable, e.g. LIYY)

Terminals +	DC 24 V e.g. LIYY white
Terminals -	0 V e.g. LIYY brown
Terminals 1, 4	Relay NO. LIYY green
Terminals 2, 5	Relay NC.
Terminals 3, 6	Relay C. LIYY yellow

-X3 (Screw terminals, optical sensor)

Terminals 1	red
Terminals 2	green
Terminals 3	blue
Terminals 4	N/C

By way of example, the wiring diagram shows the connection of two PSO+ to the RLA^{net} monitoring unit:

- Can be combined with SCR sensor cable or point sensor by means of PS printed circuit board –X1; as a result, locating function is possible
- Measuring circuit ended using terminal jumpers (or end plugs for SCR)
- Load (e.g. a valve) can be switched off on site using floating changeover contact
- Decentralised power supply possible

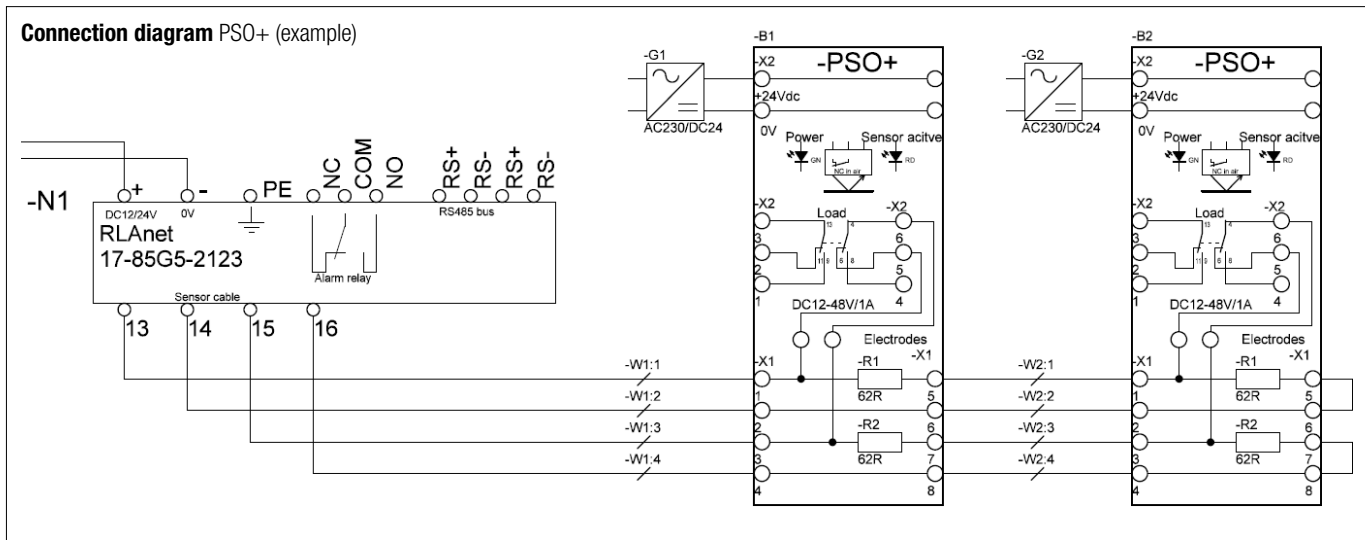

Reservation Technical data subject to change without notice. Changes, errors and misprints may not be used as a basis for any claim for damages.



Electrical connection/device connections

PSO

-X2 (Screw terminals, power supply and floating changeover contacts via installation cable, e.g. LIYY)

Terminals +	DC 24 V e.g. LIYY white
Terminals -	0 V e.g. LIYY brown
Terminals 1, 4	Relay NO. LIYY green
Terminals 2, 5	Relay NC.
Terminals 3, 6	Relay C. LIYY yellow
Terminals 2, 3	Integrated terminal resistor 220 kΩ, is removed for series connection, except for the last PSO

-X3 (Screw terminals, optical sensor)

Terminals 1	red
Terminals 2	green
Terminals 3	blue
Terminals 4	N/C

By way of example, the wiring diagram shows the connection of two PSO to the RDA01 monitoring unit:

- No locating function possible
- Measuring circuit ended using final resistance
- Load (e.g. a valve) can be switched off on site using floating changeover contact
- Decentralised power supply possible

Connection diagram PSO (example)

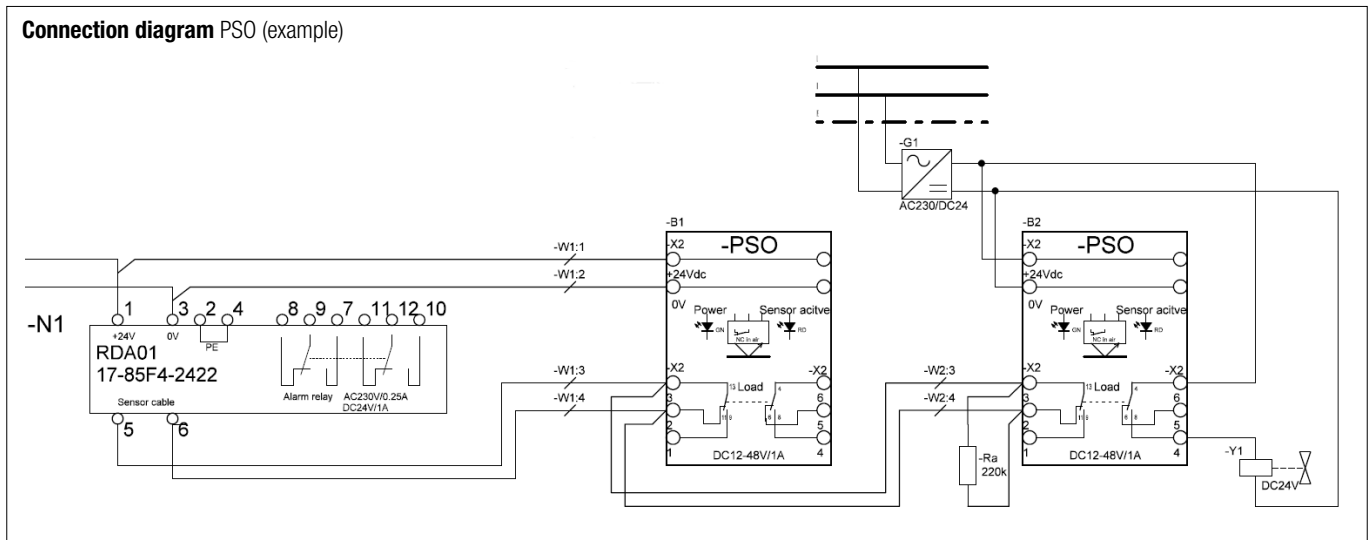

Location diagram Terminal strip

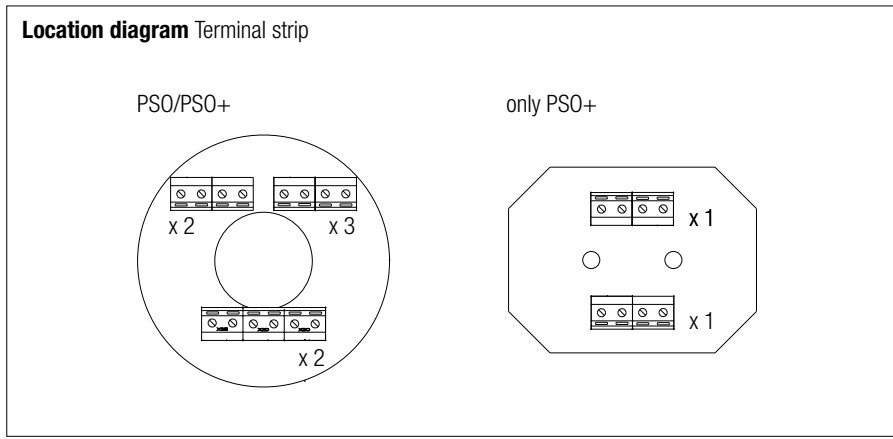

11-85M6-7D0001/B-11/2017-EHT-414087

Service Address

BARTEC GmbH Max-Eyth-Str. 16 97980 Bad Mergentheim Germany Phone: +49 7931 597 0 info@bartec.de www.bartec.de

Reservation Technical data subject to change without notice. Changes, errors and misprints may not be used as a basis for any claim for damages.